

CAD FILE:

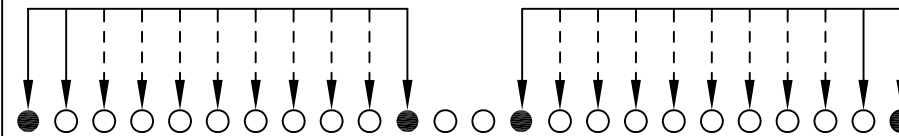

SCHEMATIC (NON-SHORTING)

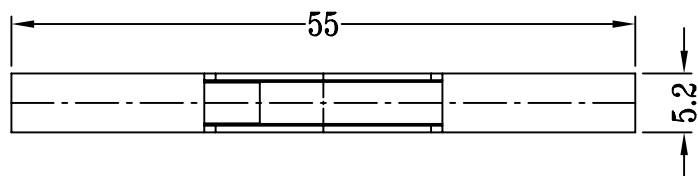
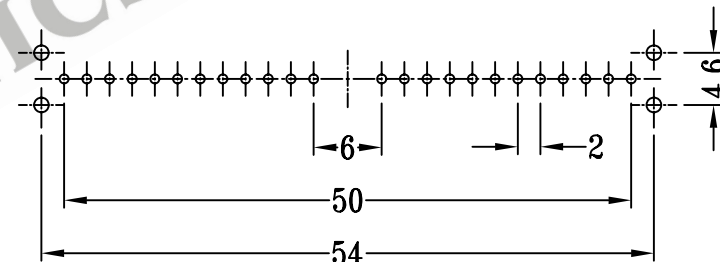
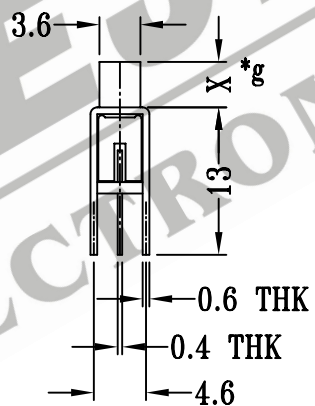
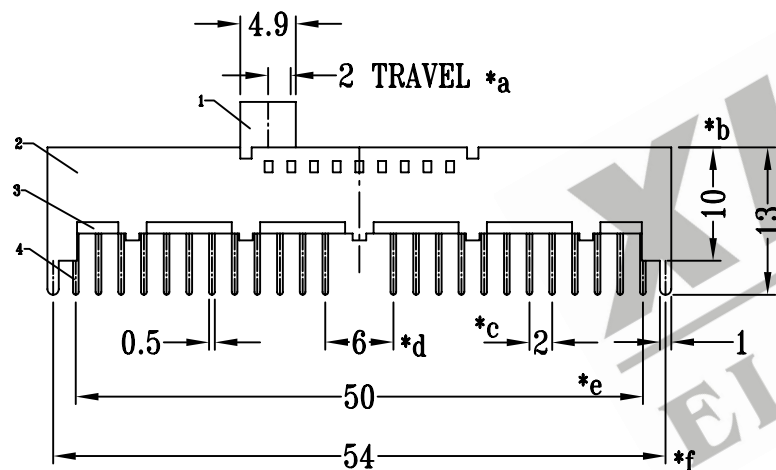

P.C.B LAYOUT

注:带"*"表示关键尺寸(7个)

NO.	PARTS	MATERIALS	Q'TY	FINISH	TOLERANCE UNLESS SPECIFIED	SHENZHEN XIEJIA ELECTRONICS CO.,LTD.					
8						ISSUE		DATE		DESCRIPTIONS OF REVISION	APPD.
7	STEEL BALL	STEEL	1	NATURAL	WITHIN: 1.5±0.1mm OVER : 1.5±0.2mm	TITLE : VERTICAL SLIDE SWITCH		UNIT : MM	DRWG NO.: XJ-DR-SS29D01-00		
6	SPRING	STEEL WIRE	1	TEMPER		MODEL: SS-29D01		SCALE: 3:2	DWN.	ZHOUYU	2005-5-11
5	CONTACT CLIP	PBS	2	Ag CLAD		ALL MATERIALS MUST BE COMPLIANT TO ROHS			CHK'D	FANGYING	2005-5-11
4	TERMINAL	BRASS STRIP	24	Ag PLATED OVER Ni PLATED					APPD.	KANGXINAN	2005-5-11
3	BASE	PHENOLIC RESIN	1	NATURAL							
2	FRAME	STEEL STRIP	1	Ni PLATED							
1	KNOB	POM	1	BLACK							